

CISON

V8-OHV Engine Model Operation Manual

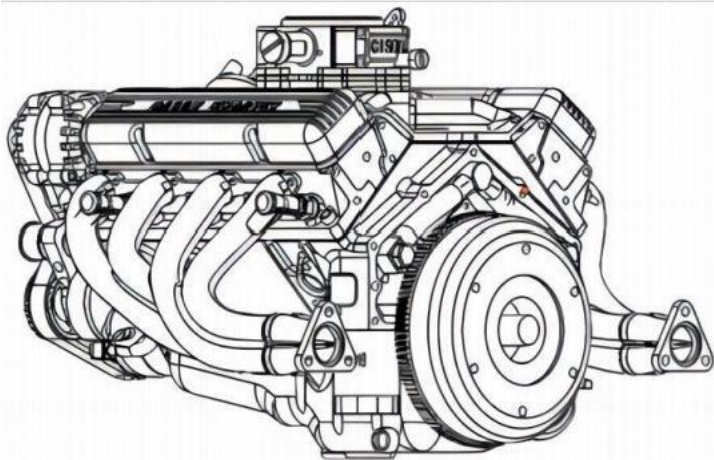

Copyright January 2024, reserved by CISON, revised March 2024(ST)

WARNING: No part of this manual may be reproduced in any form.

No part of this manual may be reproduced in any form without the written approval of CISON.



Download the latest official manual:

<https://vortrix.com/>

FaceBook Technical Discussion:

<https://www.facebook.com/groups/feed/>

About Your Engine

Remember, your engine is not a "toy" but a highly efficient internal combustion engine. Its power output can cause injury or other effects. Do not modify or disassemble it. As a professional user, ensure the engine operates safely and cautiously. If your CISON engine is to be acquired by someone else, we kindly request that you pass these instructions to its new owner.

The following recommendations apply to all production engines. Incorrect operation or neglect of safety may result in engine damage or hazards.

Warning: These events may involve serious injuries (in extreme cases, even fatal).

- Model engine fuel is toxic. Avoid contact with your eyes or mouth. Always store it in clearly labeled containers and keep it out of reach of children.

- Model engine fuel is also highly flammable. Keep it away from open flames, excessive heat, spark sources, or anything that could ignite it. Do not smoke or allow others to smoke near it.

- Never operate your engine in an enclosed space. Model engines, like car engines, produce deadly carbon

monoxide. Only run your engine in open areas.

- Model engine generates significant heat. Do not touch any part of the engine until it has cooled down.

- Contact with the muffler, cylinder head, or exhaust manifold may cause severe burns.

Please note:

This engine is designed for scientific experiments, model demonstrations, and driving model vehicles. Do not attempt to use it for any other purpose.

Securely install the engine in your model using the appropriate screws and lock nuts as recommended by the manufacturer.

During startup, some noise will occur. To mitigate this, you can purchase a matching muffler exhaust pipe from us or place the engine away from populated areas, as the operating noise may disturb others.

It is strongly recommended to use safety glasses. Ensure that electrical plugs or battery wires do not come into contact with rotating parts. Also, make sure the throttle lever connection is secure.

For safety, keep all spectators, especially children, at least 3 meters away from the engine when starting it.

To stop the engine, fully close the throttle. In emergencies, you can pinch the fuel line in front of the carburetor to cut off the fuel supply. Do not attempt to remove the flywheel or starter pulley.

Basic Parameters

Brand: CISON
Engine Type: Gasoline Internal Combustion Engine
Valve Train Type: OHV
Model: V8-OHV-44
Material: Metal
Color: As Shown
Overall Dimensions: 156×117×99mm
Bore: 18.5mm
Stroke: 20.5mm
Weight: 1.7kg
Product Form: KIT(Disassembled Version)/Complete Version
Displacement: 44cc
Cylinder; V8
Stroke: 4-Stroke
Speed: 1500-10000rpm
Power: ≈5.5ps
Cooling Method: Water-cooled
Starting Method: Electric Start
Ignition Method: CISON V8 Engine-Specific CDI Igniter
Sparkling Plug Type: 3/1640 Threaded Spark Plug(not included)
Lubrication Method: Independent Lubrication System
Fuel Type: 92#or higher gasoline
Oil Type: 4T Oil,10W50OiV25ML Recommended
Starting Power: 12V Battery(not included)
Packing: Exquisite Gift Box
Packing List: Engine Parts*1 set、Instruction Manual*1

Structure & Components

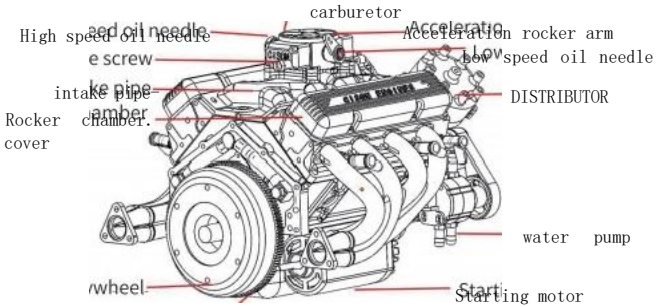

Start the large gear

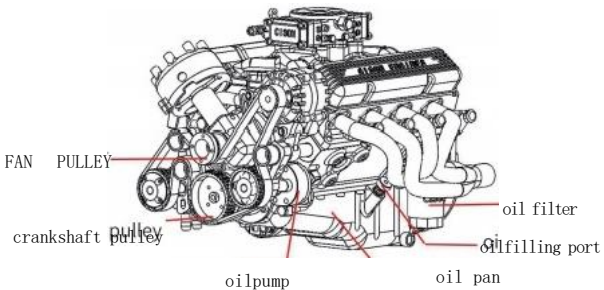

Engine View

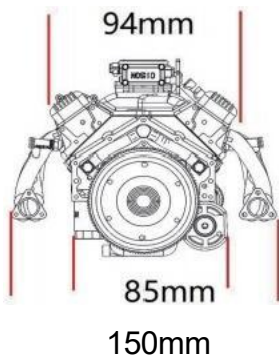
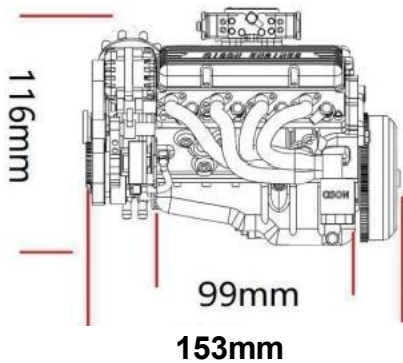

Required Tools and Materials

Prepare the following items:

1) 92/95# gasoline

2) 4T engine oil [recommended 10w-50]



















3) 3mm small flat head slotted and cross screwdrivers, 1.5mm/2.0mm/2.5mm hexagonal screwdrivers, 1.5, 2.0mm hexagonal ball screwdrivers, 6mm spark plug socket, tweezers, rubber hammer

4) 12v high power supply (at least 15a current)

5) Quick-drying glue, silicone sealant, medium strength screw glue

6) Coolant (preferably with lubricating oil)

Packing List Map

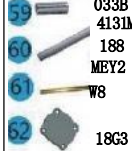
 <p>1 12pcs M2X5</p> <p>2 M2. 5X</p>	 <p>3 100pe M3x18</p> <p>4 10p M22</p>	 <p>5 42PCS M2.5X6.5</p>	 <p>6 1PCS M8X4</p> <p>7 3PCS M2X4</p> <p>8 6PCS</p> <p>9 1PCS Oil pan plug</p>	 <p>10 1PCS M4X5</p> <p>11 3PCS M8X6</p> <p>12 1PCS M4X7</p> <p>13 1PCS 6x4x1</p> <p>14 1PCS A7x1x1</p>
 <p>16 M25XB</p> <p>18</p>	 <p>17</p> <p>18</p> <p>19</p> <p>20</p>	 <p>21 1pc m4x4</p> <p>22 1pc 4x8x0.1</p> <p>23 1pc 4x8x2.7</p> <p>24 6pc m2x4</p> <p>25 1pc m2x4</p>	 <p>26 05P蛋</p> <p>27 13P3</p>	 <p>28 07P1 04P2X3</p> <p>29 1R3</p> <p>30 1强 B</p> <p>31 1 020</p>
 <p>32</p> <p>33</p> <p>34</p> <p>35</p> <p>36</p>	 <p>37 16pc 7x1mm</p> <p>38 2pc 5x1mm</p> <p>39 1pc 9x0.5mm</p> <p>40 1pc 8x1.6x1.4</p> <p>41 1pc</p>	 <p>42 24PCS 22x1mm</p>	 <p>43</p> <p>44</p> <p>45</p> <p>46</p>	 <p>47 2P 8213x02</p> <p>48 0PCS</p> <p>49 M6 0PCS</p> <p>50 2PCS 2x4mm</p> <p>51 1PCS 3x36.5mm</p>
 <p>52</p> <p>53 1/2x14x4</p> <p>54 1PCS</p>	 <p>55</p>	 <p>56 16pcs</p>	 <p>58 C1aRpe</p>	 <p>59 033B 4131M</p> <p>60 188 MEY2</p> <p>61 W8</p> <p>62 18G3</p>

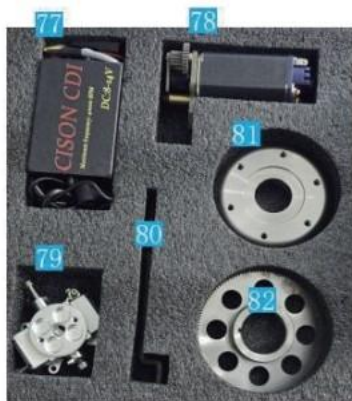
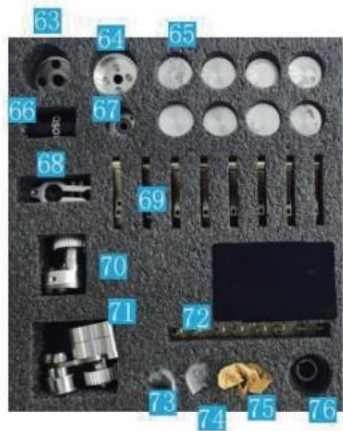

Assembly Steps

1. Clean the cylinder sleeve again to prevent dust from scratching the piston.

Remove the cylinder sleeve: it can be taken out directly.

Use non-metallic material to gently tap it out from the bottom.

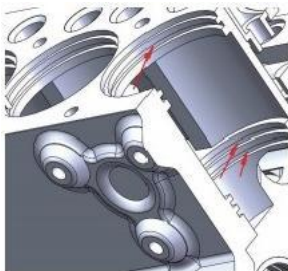

Box Number: #42

Apply lubricating oil to the sealing ring to prevent any damage

(Install 3 sealing rings per cylinder)

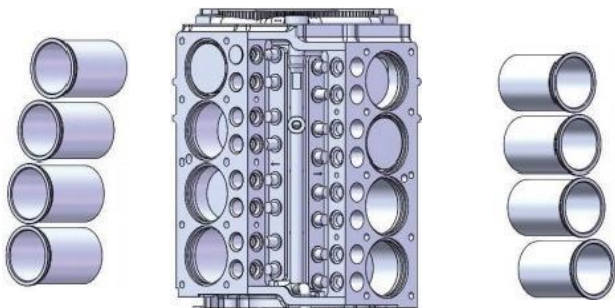

Apply silicone sealant here

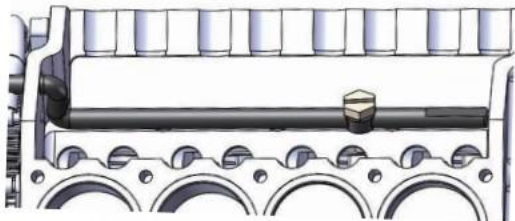
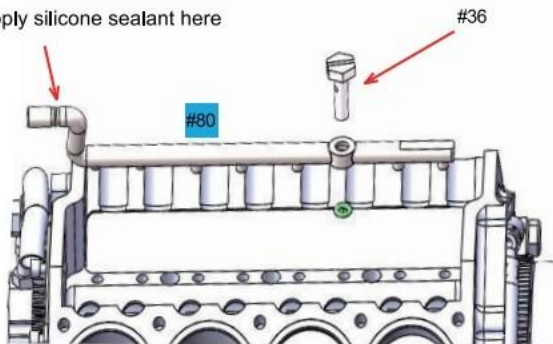

Install the tappet bushing assembly as shown
Install the 6 fixing screws(number #24)

#72

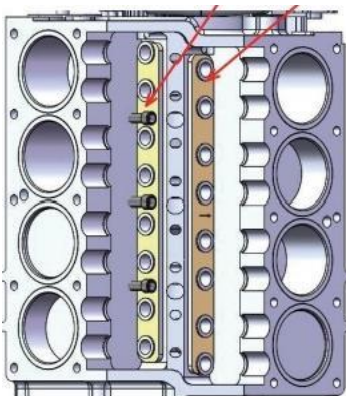

TOP mark upward

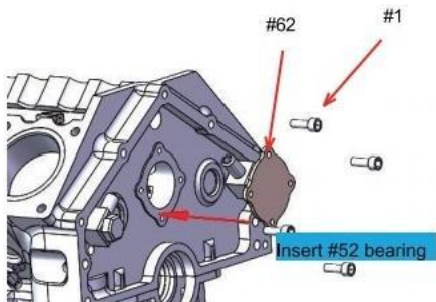

Apply silicone sealant to the cam sealing cover and tighten the screws

#Silicone tube #32
2.5x5

#43

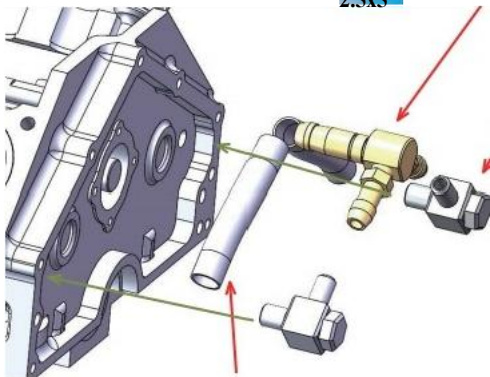

Cut to the right length

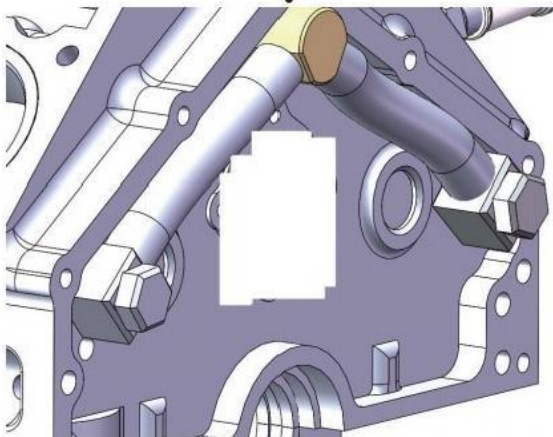

Assemble the Crankshaft

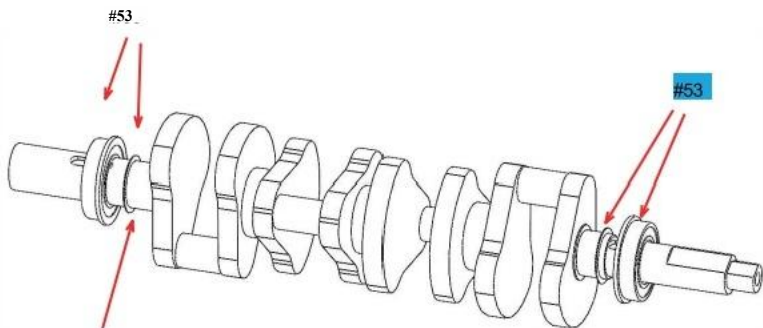

Gasket:0.25*8*11

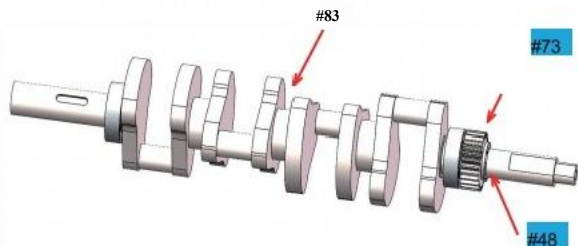
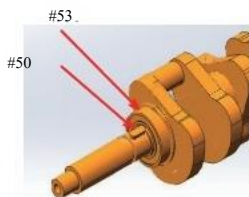

#55-Put in 3 bronze bearings and add oil

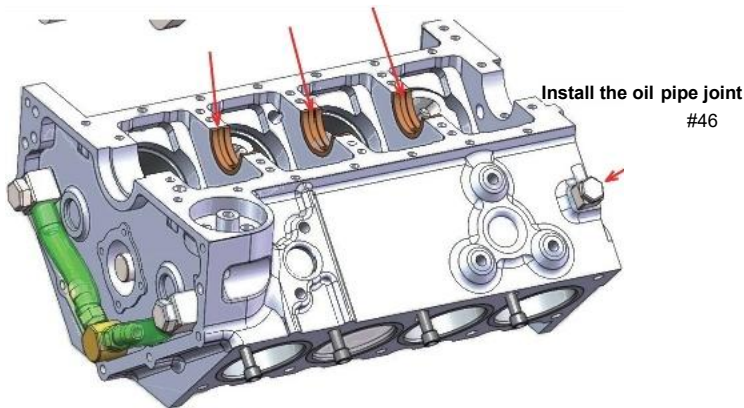

#7 Please align the screw with the small hole in the middle of the copper bearing

#7

Remove the crankshaft bearing seat screws

Note: The bearing seats are matched with each other, please do not use them interchangeably

Use medium-strength screw glue (blue) for the bearing seat screws

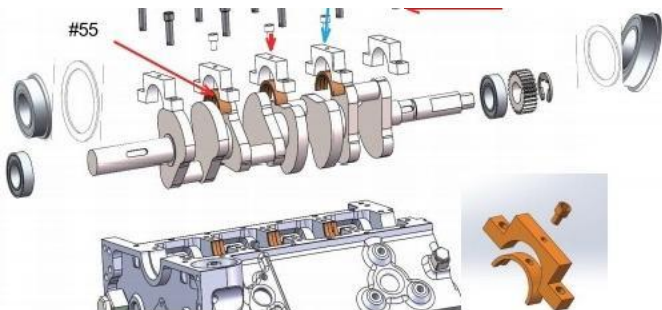

Assemble the crankshaft parts assembly as shown. Please note that the #7 screw must be aligned with the bearing hole before tightening, otherwise the crankshaft may get stuck.

#40(with groove facing the cylinder body)

Install the
oil seal

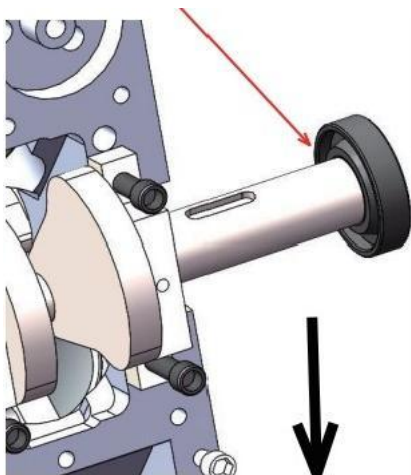

Install the
oil seal spacer

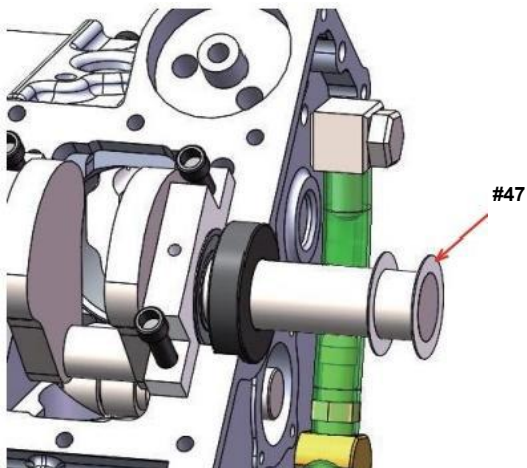

#82

#76

#49

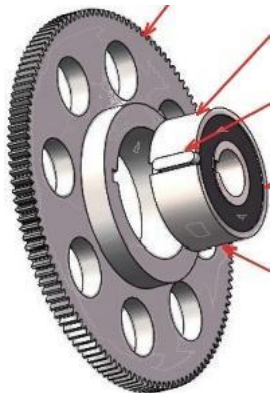

Black facing gear boss

Clean the anti-rust oil on the bearing surface and use screw glue to fix the bearing and gear on the surface

Starter gear bearing

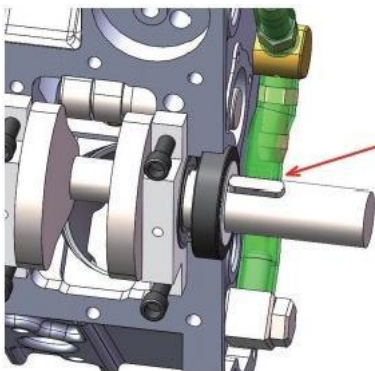

#49

Mounting
keyway

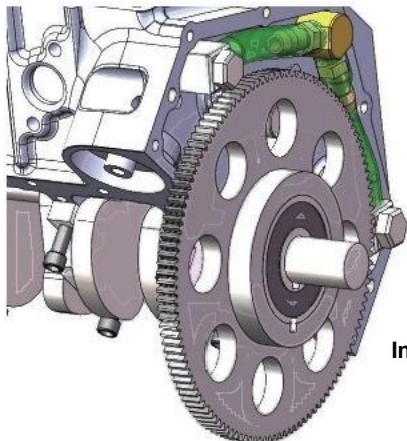

Install the starter gear

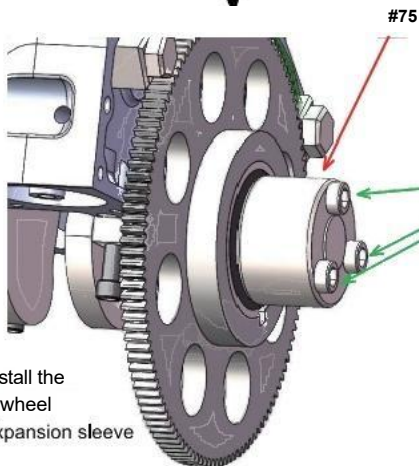

#75

Loosen the 3 screws
and put them into
the crankshaft

**Install the
flywheel
expansion sleeve**

Assemble the Flywheel

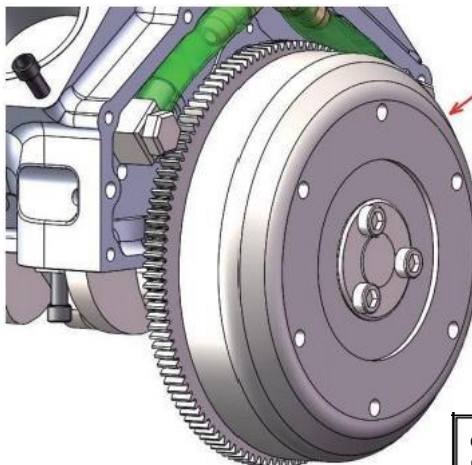

#81

After the flywheel is put in, adjust the clearance. The flywheel should be at least **0.5mm** away from the starter gear. Then tighten the three screws slightly in sequence, and tighten them again at the end.

Install the oil filter

Common mistakes:
Directly tighten the first screw and then the second screw.

#66

It is recommended to add a magnet and sponge filter inside

#60

It is recommended to apply low-strength anaerobic glue

#White gasket

#61 has a blue mark

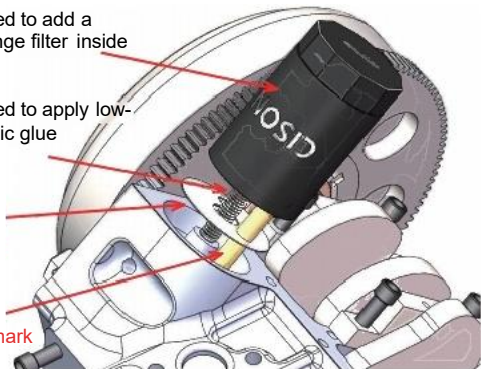

Prepare 8 Piston Assemblies

#56

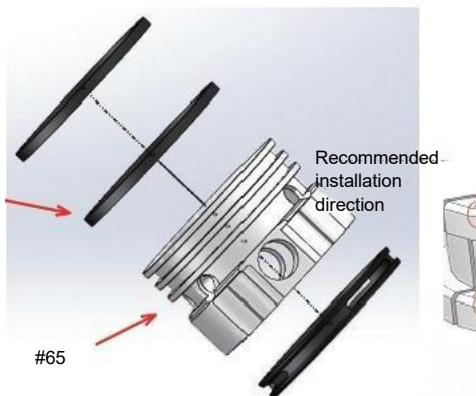

#58

Note: The piston ring is made of cast iron. If it is slightly rusted, please soak it in wd40 to clean it.

Please note that the chamfer direction of the oil ring faces the top of the piston. Do not install it in the opposite direction.

Tip: After installing the 1, 2, and 3 piston rings, the piston ring openings #28 should be staggered 180°

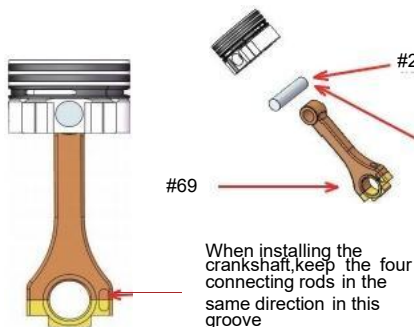

#28

#69

The piston pin can be fixed at both ends with anaerobic glue, please do not touch the connecting rod to prevent the piston pin from moving during operation.

When installing the crankshaft, keep the four connecting rods in the same direction in this groove

1. Install the piston into the cylinder in sequence
2. Apply lubricating oil to the piston and connecting rod surface
3. Keep all connecting rod grooves facing the flywheel

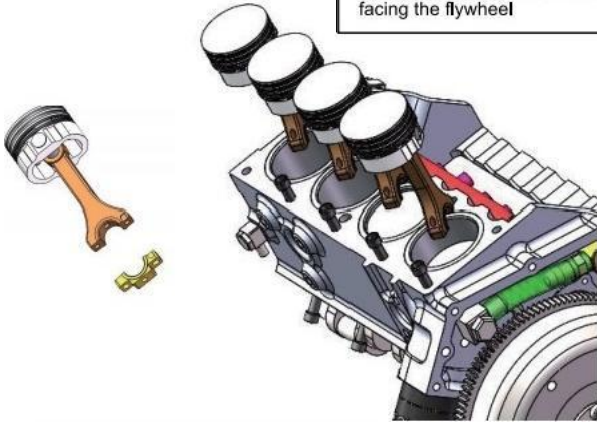

Apply silicone sealant to the entire contact surface

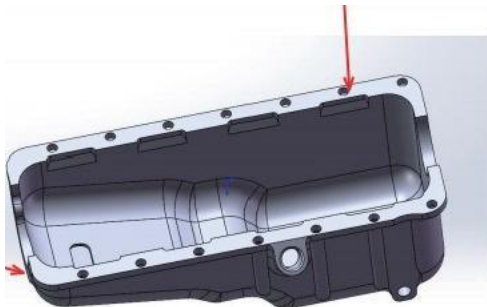

The plane uses sealant

#51-Pointed end facing the cylinder body

Distinguish the copper tube of the oil filter

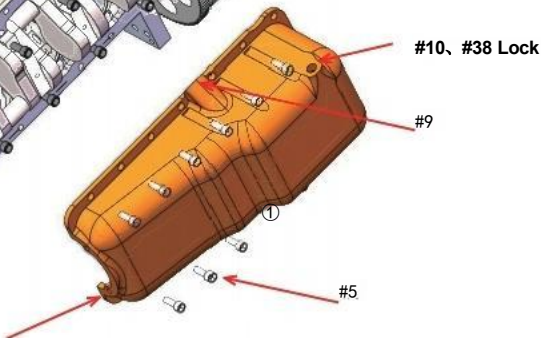
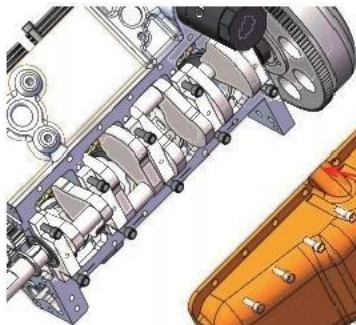

The plane uses sealant

The bearing has been installed in the previous step and can be ignored.

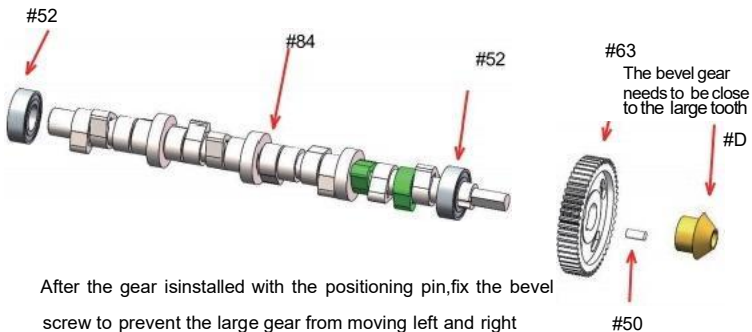

After the gear is installed with the positioning pin, fix the bevel screw to prevent the large gear from moving left and right

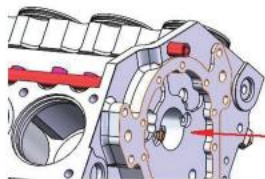

Put the camshaft
into the hole

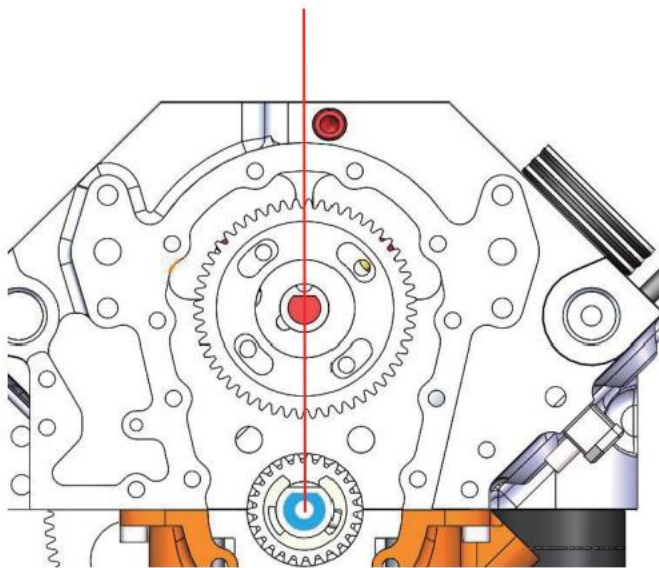

Crankshaft and cam plane vertically upward

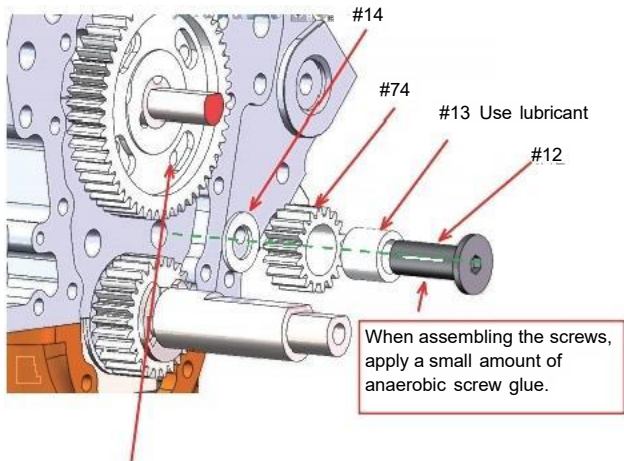

When assembling the gears, it may not be possible to ensure that the crankshaft gear and the camshaft gear are vertically upward at the same time. The position can be fine-tuned by adjusting the 4 screws on the gears. After adjustment, the screws must be re-tightened to avoid loosening during operation. It is recommended to use **low-strength screw glue**.

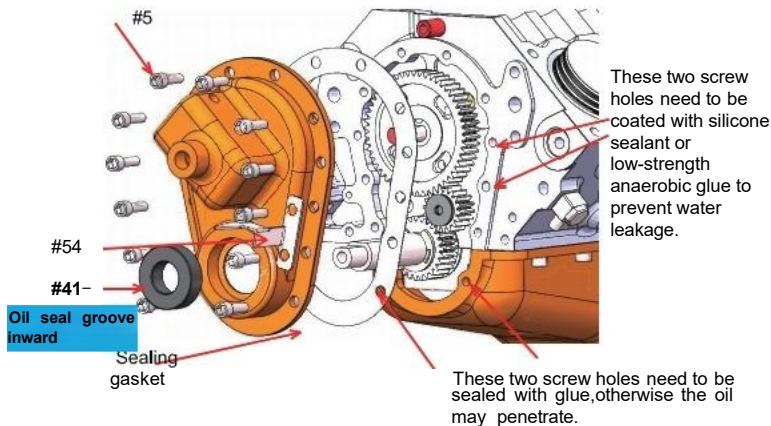

After Installation

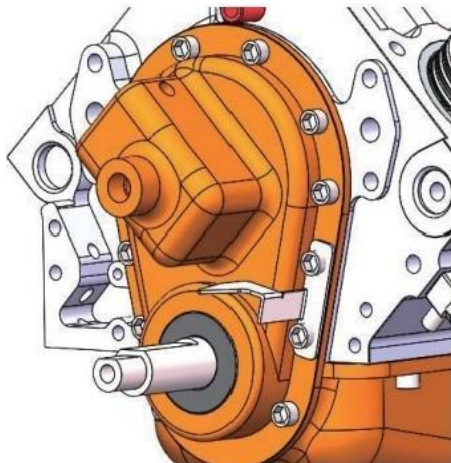

After installation, turn the crankshaft D axis plane upwards and then turn the pointer to zero position

Note: The default pointer angle is wrong and the reference must be corrected manually.

#64
Align the crankshaft
plane
Locking screw

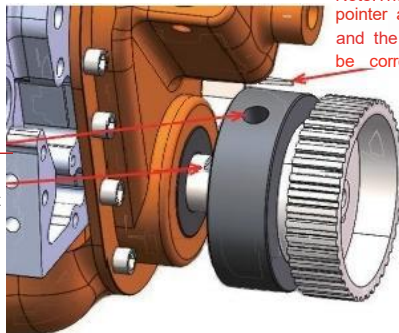

Install the Fan Idler Install the Oil Pump Base Bracket

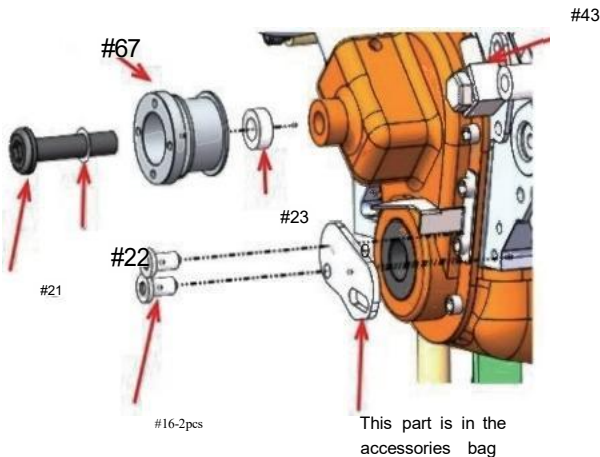

Install the Pump

M44

Use after connecting to
water pipe

#8 Bundled silicone tube

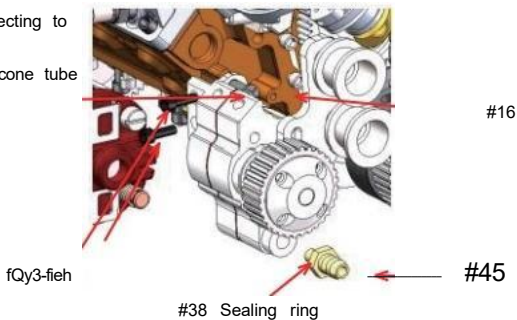

Oil Pump Assembly

Please turn the four screws out

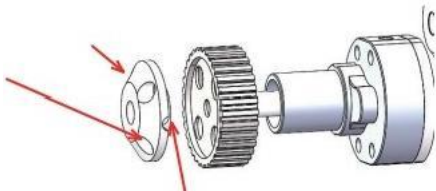

Please loosen the M3 fixing screws on both sides

Then take out the pulley. It is recommended to use a puller tool to pull it out. It is not recommended to grab the pulley and pull it out directly, which can easily pull out the input shaft.

Note: Please do not let the gear shaft come out with it

If it has come out, please re-align the gear D hole

The gear is made of mixed carbon material. If it is not aligned with the D hole and forced into it, it may damage the gear

Assemble the fixing bracket according to the reference diagram

Then tighten the screws on the front and sides of the synchronous wheel.

Please note:

The synchronous wheel drive shaft position should be restored to the position before disassembly

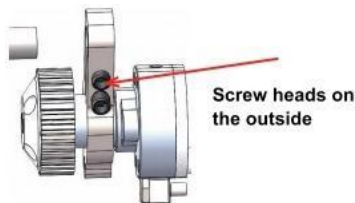

Installation Diagram

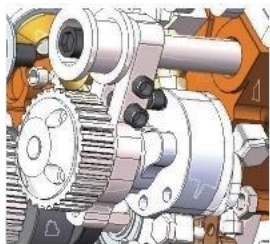

After installation, install the belt, adjust the angle, and tighten the two screws.

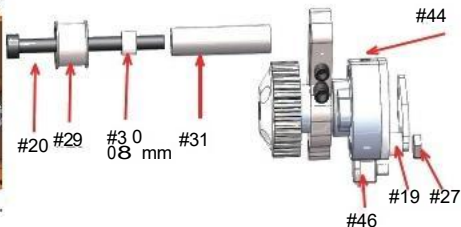

#11

First install the screws and tighten them slightly

It is recommended to add low-strength screw glue

To prevent the screws from loosening due to engine vibration

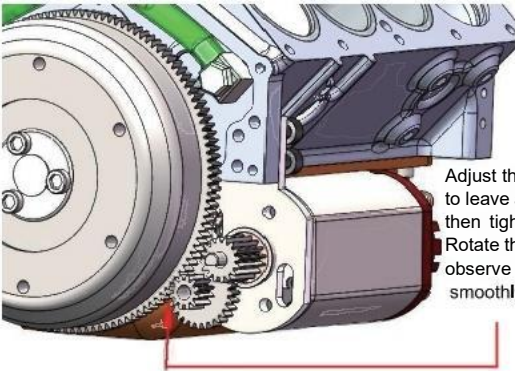
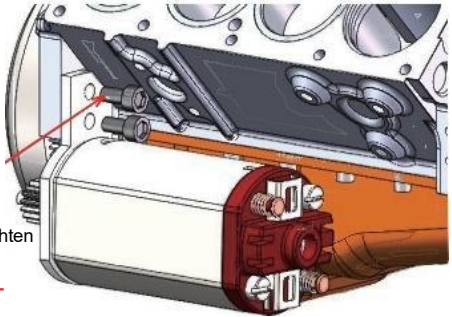

Adjust the gap. It is recommended to leave a gap of A4 paper and then tighten the #11 screw. Rotate the flywheel clockwise to observe whether the gear runs smoothly.

Common mistakes:

Gear clearance is too small: it will cause the starter to be weak, and the load is too large: it will cause the risk of gear sweeping

Install Valve Oil Seal(Optional)

Remove the 8 intake valve (large valve)springs,snap them in,and start installing the 8 valve oil seals

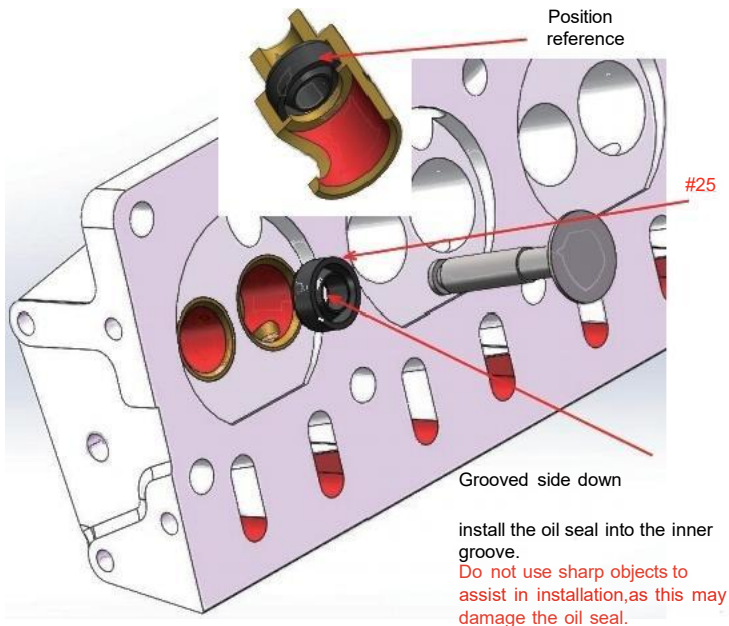

Note:After reinstalling the valve,make sure there is no foreign matter on the valve contact surface.Otherwise, valve leakage will cause failure to start.

Install the Cylinder Head

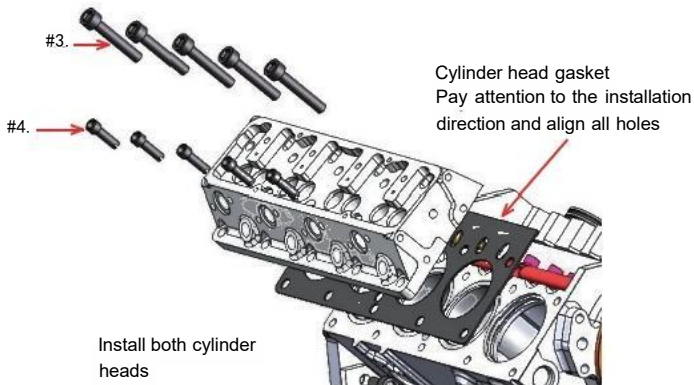

#59 Place 16 tappets into the positions indicated in the picture (the tappet screw grooves face the cylinder head)

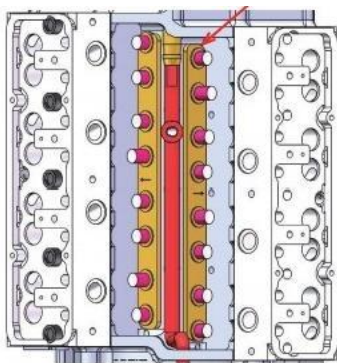

Install the Actuator

Put 16 push rods into both cylinder heads

Put the push rod (inside the gasket bag) into the screw head

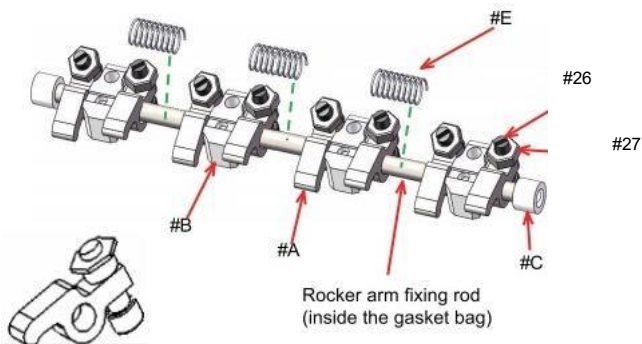
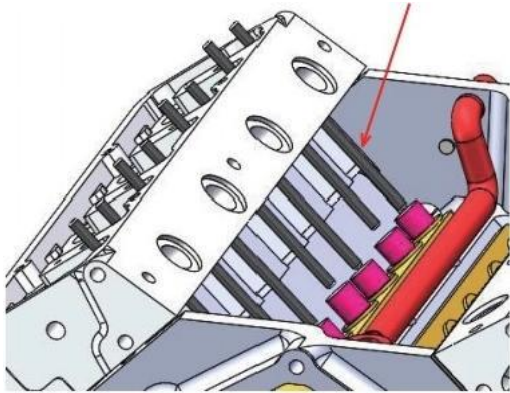

Assemble 2 sets of rocker arm assemblies as shown in the figure

Install the Rocker Arm Assembly

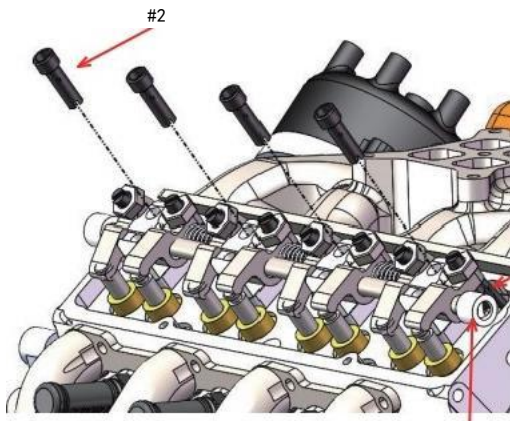

Put the push rod (inside the gasket bag) into the screw head

Adjust the fixed wheel clearance to ensure the rocker arm can move normally

Important:

Adjusting valve clearance

1. Rotate the flywheel to observe one of the rocker arms to be adjusted.
2. After the rocker arm moves downward, continue to rotate the flywheel until the current cylinder piston reaches the top dead center, then continue to rotate about 30° to ensure that the current rocker arm is completely closed.
3. Please use a screwdriver to rotate the #26 screw to adjust the rocker arm clearance to about 0.1mm (Note: there is still 0.1mm distance after tightening the #27 nut).

Adjust the current clearance valve to fully closed state

0.1mm

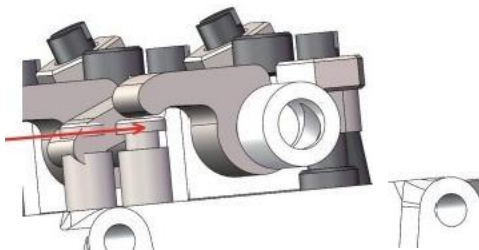

Install the Air Intake Pipe

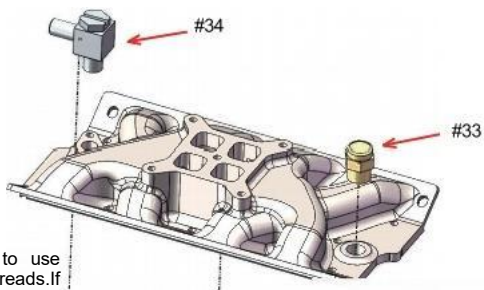

It is recommended to use sealant on the threads. If you encounter a screw blocking the installation, you can remove the screw first.

Cut the 3x6 silicone tube to fit the three-way faucet of the tank and tie the joint with the tape provided in the bag.

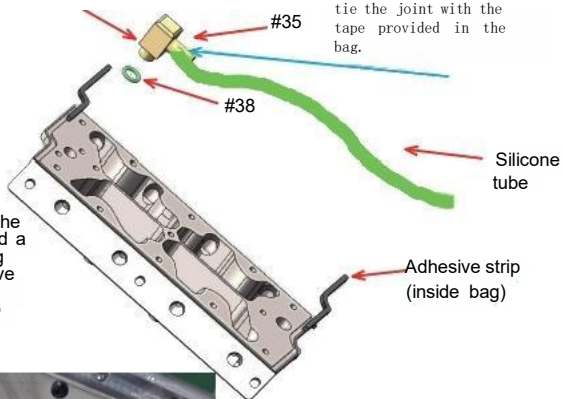

When installing the strip, you can add a little quick-drying glue to the groove (left, middle, right) to make the strip stick.

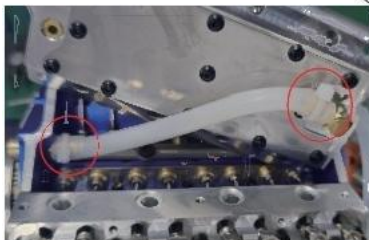

The other end is also tied with a zip tie

Install the air intake pipe

Cut the 3x6 silicone tube to fit the three-way faucet of the tank and tie the joint with the tape provided in the bag.

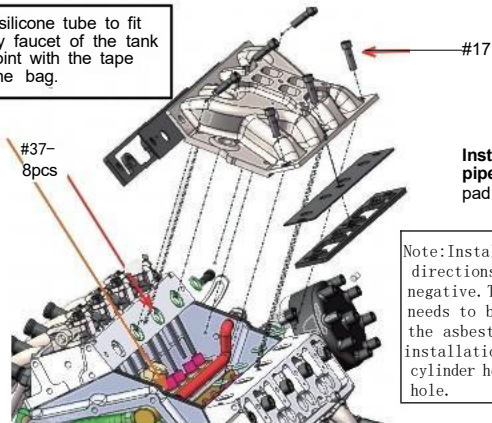

Install the intake pipe insulation pad

Note: Installation has two directions: positive and negative. The fiberboard needs to be aligned with the asbestos gasket installation hole and the cylinder head installation hole.

Install the Carburetor

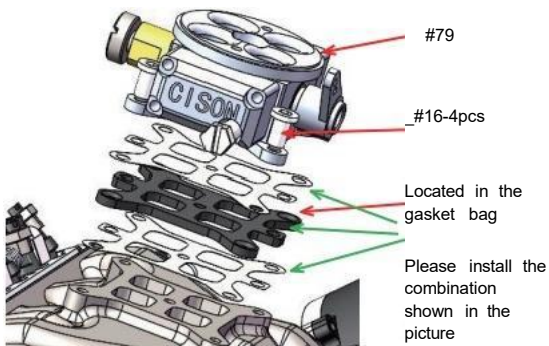

Belt installation, Pipe Connection

Oil pump link



Water hose and belt

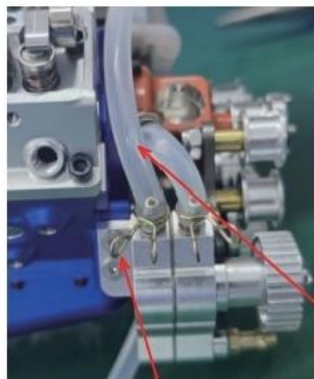

2.5x5mm

#8

Cooling of cylinder head

1.Prepare three-way joints and silicone tubes

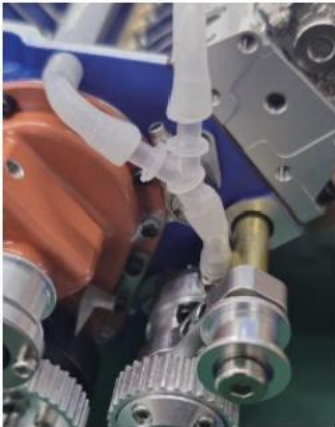

2.Install the Y three-way joint and oil pipe according to the schematic diagram

3.Remove the top screw of this hole in the cylinder head,and install a three-way joint and a right-angle joint [the accessories are located in the accessories bag]

Connect the Y-type oil pipe to the oil pump

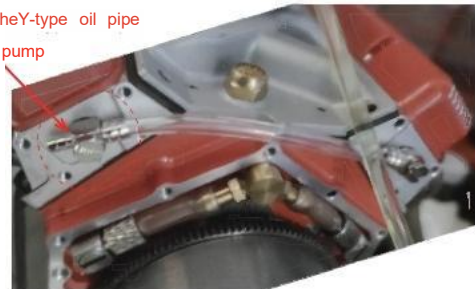

Distributor Cable Installation (Optional)

1. Take out the steel wire rope and rope fixing ring in the bag, and fix the steel wire into a circle according to the diagram.



2. Cut the steel wire to the appropriate length, fix it on the distributor, and pass it through the spring sleeve. Fix the steel wire on the carburetor.



3: Fix the carburetor and adjust the tension of the cable

Fix the pullwire according to the diagram



Use nuts to secure the sleeve

Control the tension of the wire by adjusting the threaded sleeve

Note: The total ignition angle cannot exceed 30° , otherwise the performance may be reduced. Please adjust the tightness of the wire according to the ignition angle set for idle speed.

That is, when the throttle is at maximum, the distributor angle is not greater than 30°

If it is difficult to install, it can be ignored and will not affect the engine start

Install the Distributor

This valve moves downward

- 1.From the flywheel side,rotate the flywheel counterclockwise
- 2.Observe the intake valve indicated by the arrow
- 3.When the valve moves downward
- 4.Rotate the flywheel by hand while observing the plane at the end of the crankshaft
- 5.Until the crankshaft plane is vertically upward(as shown in the figure)

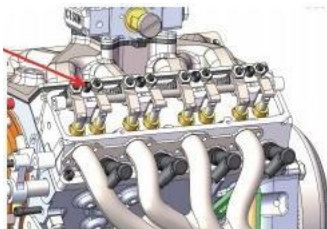

**Common failure to start errors:
Thinking that any crankshaft plane is the same**

The correct answer is that the first cylinder is in the compression stroke

- 1.Rotate the distributor gear and find the hole with a blue mark
- 2.Keep the hole in the black hole of the distributor housing
- 3.Insert the distributor into the distributor mounting hole on the front of the engine
- 4.Pay attention to the gap between the installed gears.The wrong gap will damage the gears.

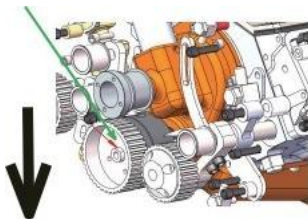

Keep the crankshaft plane vertically upward.Now,prepare for top dead centerignition of cylinder 1.

Common mistakes:

The blue hole on the distributor rotor is not aligned with the black hole on the housing,causing the ignition timing to be disrupted,thus preventing the engine from starting.



#11

Note that after installation,you can use a small screwdriver to lightly touch the blue hole to see if the rotor will swing significantly.If it does,it may cause unstable operation.You need to remove the black cover to adjust the gap and reset the distributor ignition time.

#6
Slightly tighten the screw

Distributor and Carburetor Linkage

1. Please cut the high-voltage wires provided in the bag to the appropriate length
2. Find the high-voltage boots in the bag. The long-head version is used for the spark plugs, and the short-head version is used on the distributor cover.
3. Connect 1357 on the distributor to the cylinder 1357 spark plugs
4. Connect 2468 on the distributor to the cylinder 2468 spark plugs.
5. Connect the cdi ground wire to the cylinder, and the high-voltage wire to the middle of the distributor.

①⑧④③⑥⑤⑦②

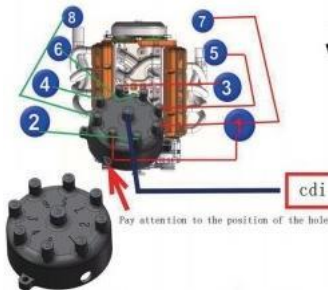

1. Please confirm again that when the crankshaft plane is facing upward, the small pointer points to the scale on the black wheel at 0 degrees.
2. Install the sensor plug on the distributor and connect the high-voltage wire correctly.
3. Rotate the flywheel slowly by hand to observe the angle at which the Hall pointer is sensed, and then adjust the sensing angle to 10°.

Adjustment method:

Loosen the screws on the front and side of the distributor, rotate the mounting bracket at the bottom of the distributor, rotate toward the flywheel end to increase the angle, and rotate toward the front to reduce the angle

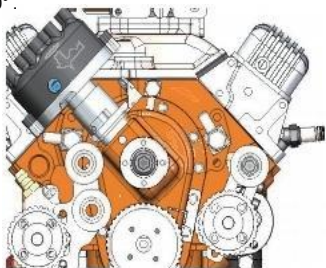

Angle degree questions:

1: Why is it 10°

Q: Because 10° is easy to start and stabilize at idle

2: Can it be other degrees?

Q: Yes, you can set it according to your own experience, the idle speed is generally 0~15°

3: What does distributor linkage mean? What is the maximum angle?

Q: Distributor linkage changes the ignition angle according to the size of the throttle to make the combustion more complete and the top speed higher. For example: 10° at idle, 30° at top speed. The maximum angle is recommended not to exceed 30°, otherwise it may not increase the speed but reduce it

3: Can linkage be omitted?

Q: Yes, if you use the speed for a long time and the speed does not exceed 6000 rpm, you can ignore it

Install the Rocker Cover

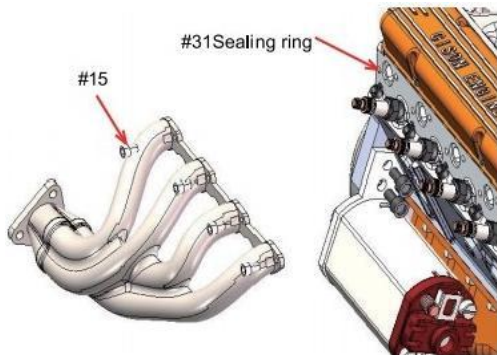

The installation hole has a small space. It is recommended to use a screwdriver to slowly insert all the screws into the exhaust pipe first, and then slowly rotate them into the cylinder head in sequence.

Apply silicone sealant to the bottom of the cylinder head to prevent oil leakage. Note: There are different directions for installing the cylinder head. Refer to the instruction diagram.

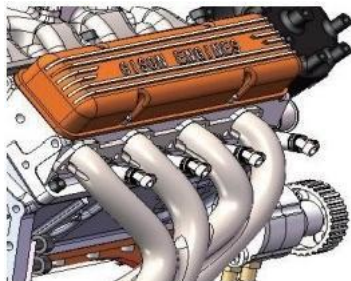

Real Shot Reference



CDI trigger time and magnet position

Camshaft position

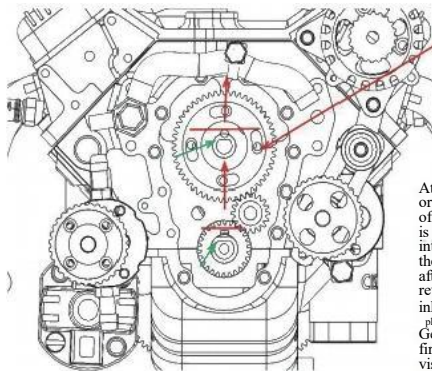

If the position is incorrect these four screws can be adjusted

Timing: The cross-section(D-axis) on the flywheel and crankshaft is perpendicular upwards

Attention: If the timing is advanced or delayed, it will affect the state of the other half of the cylinder. It is recommended not to install the intake pipe temporarily. Then install the spark plug, rotate the flywheel after installation, and observe the reverse injection when preparing to inhale on the other side. If spraying, please readjust the gear position. Generally, the exhaust valve of the first cylinder on the right that is visible from the gear is just closed

Subscribe to our YouTube:

<https://www.youtube.com/c/CISONENGINE>

Electrical Circuit and Water Pipe Wiring Diagram

Keep the ventilation open, otherwise it is easy to cause excessive pressure and leakage.

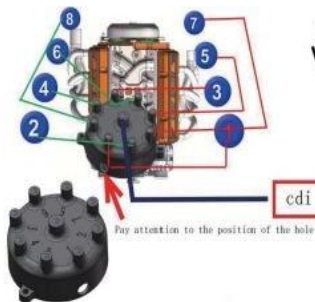
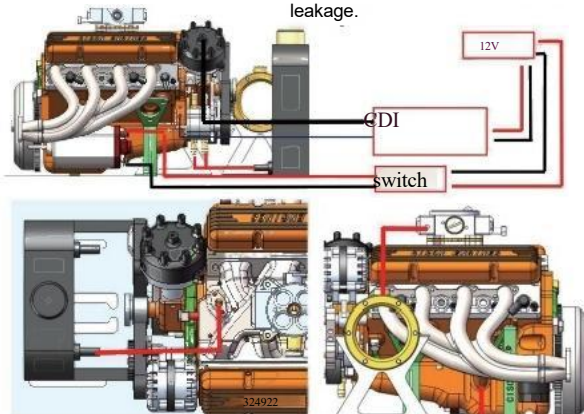

After plugging in the high-voltage wires in order, insert the dedicated Hall connection wire, connect the DI to the 12V power supply (JST plug), rotate the flywheel to observe whether the Hall LED light is on.

Observe whether the compression point of cylinder 1 (intake valve open, crankshaft d-axis cross-section facing upwards) lights up the indicator light. If the indicator light is on, turn the crankshaft clockwise and backward by about 5°, then rotate and fine tune the distributor housing until the indicator lights up. If the ignition tin is incorrect, the indicator light will still light up (for example, it is currently ignition for cylinder 2). Therefore, it is recommended to use a transparent silicone hose to connect the high-pressure line of cylinder 1 and the spark plug of cylinder 1, and observe whether the spark plug of cylinder 1 produces high voltage electricity.

Preparation for Engine Starting

Check the integrity of the product

For safety reasons, it is strongly recommended not to disassemble the engine or attempt to start the mechanism. If there are any starting problems, please contact your local dealer or CISON's technicians for help. CISON will provide high-quality after-sales service if you need to send the engine back to the factory for testing. However, if any problems occur due to unauthorized disassembly, you will bear any corresponding responsibilities and expenses. Before starting

1. Please check whether the CDI is powered on normally, turn on the switch, and then turn the flywheel to observe whether there is a high-voltage spark on the top of the spark plug. If there is no high-voltage spark, a) Please check whether the power is connected.
b) Is the voltage normal.
c) Is the Hall sensor damaged, etc.

2. Please open the carburetor throttle to the maximum, then block the air intake with your hand, turn the flywheel for more than 3-5 turns, let the fuel enter the cylinder in advance, and then start the engine.

The carburetor needle may be slightly different. If it cannot start, adjust the main oil needle to 2.0 turns, and the auxiliary oil needle is slightly tightened and rotated counterclockwise for about 0.5 turns.

Then, try to start but it may not be accurate.

Ambient temperature, fuel tank height, etc. may affect it. Please operate according to your experience.

It is recommended to use the original small fuel tank, which will make your model more beautiful and harmonious. Of course, we can also sell some other types of fuel tanks separately.

Fuel:

The engine of this model is designed to use gasoline, and the oil pan needs to add 25ml of oil. V8 temperature is higher and high viscosity oils are recommended.

Fuel tank:

Fuel Line:

Use Tygon type tubing, do not use silicone as it is not suitable for gasoline based fuels. The included fuel line can be easily connected to the carburetor's fuel inlet with needle nose pliers.

Fuel Needle:

Main fuel needle 2.0 turns, auxiliary fuel needle slightly tightened 0.5 turns counterclockwise. The fuel needle is preset at the factory, but may need small adjustments due to fuel type/
□ temperature/altitude. Turn the fuel needle clockwise to make the mixture leaner, and turn the fuel needle clockwise to make the fuel mixture richer.

Idle Speed: Idle speed can be adjusted by turning the small hexagon screw. Turning this screw clockwise increases idle speed, and turning this screw counterclockwise decreases idle speed by closing the throttle opening.

Engine Operating Instructions

Engine Start/Run/Stop

(1) Check the engine wiring from the base, connect the tank pipe, and install the 12V battery.

(2) Fill the tank with gasoline (25ml of engine oil in the oil pan). After filling, fully open the throttle lever, put your finger on the opening of the carburetor, and rotate the flywheel clockwise 3-5 times. Let the fuel enter the cylinder completely and make sure there is no air in the oil circuit.

(3) Turn on the power switch, press the start switch, and then open the carburetor damper to about 2mm. For the first start, block the air intake for 2-3 seconds with your hand to facilitate the entry of fuel into the cylinder. If it still cannot start, please refer to the paper manual for instructions.

We recommend keeping the engine speed low during the first few runs to allow the engine to be properly lubricated and shorten the running-in period. The engine surface and exhaust pipe components do get hot, so avoid direct contact with the cylinder and exhaust pipe with your hands during operation.

Engine Commissioning

Rich oil:

When the engine has more fuel, emits black smoke or accelerates slowly, it means that the engine has too much oil. Please turn the main oil needle clockwise, and gradually reduce the main oil needle in units of 10° until the engine exhaust sound is soft and powerful.

Lean oil:

If the engine sound is too sharp, like the sound of dry friction between metals, the temperature rises rapidly, and the engine stops immediately after acceleration, it means that the engine oil is insufficient.

Please turn the main oil needle counterclockwise, and gradually reduce the main oil needle in units of 10° until the engine exhaust sound is soft and powerful.

The carburetor does not enter the oil: It may be that the needle valve is completely closed or blocked.

Carburetor injection:

The valve timing is incorrect, the valve is leaking, and the valve clearance is too small (the correct value is 0.1mm).

There is compression but it does not start:

The CDI igniter is damaged, the sensor is damaged, and the power supply fails.

Idle speed is too high:

The carburetor is not debugged correctly, the left and right cylinders are unbalanced, the cylinder pressure is insufficient, and the valve timing is incorrect.

Sudden start, no compression:

It is likely that the valve structure is misaligned or there is foreign matter in the valve.

Engine overheating:

Make sure there are cooling measures, whether thinner gaskets have been replaced to increase the compression ratio, and whether lubricants have been added to the fuel.

How to achieve ultra-low idle speed:

Replace an oversized flywheel and reduce the compression ratio.

Care and Maintenance

Maintenance Methods

This is a high-precision machine that requires regular cleaning. Due to the influence of the environment and fuel during use, the engine parts will wear and corrode. You can perform basic cleaning and maintenance to keep it in good condition.

To keep the carburetor in good condition, it is important to clean it carefully and remove dirt and grease from the air intake.

If an air filter is used, make sure it is clean and free of obstructions.

If the air filter has been used for more than an hour, it should be replaced in time to ensure normal operation. When removing the contaminated air filter element, be careful to avoid letting dirt enter the carburetor.

Spark plugs are considered consumables and must be treated as such. Running a spark plug for a long time will not guarantee the normal operation of the engine, but you can prolong its life and maintain engine performance by using it with caution. Use appropriate tools when disassembling the engine. Use the right amount of 92# gasoline. Do not over-tilt the engine and do not connect the battery when making adjustments.

If the spark plug is burned or no longer provides optimal performance, it should be replaced. For example

1. Ceramic cracks and leakage
2. Electrode burns
3. Soaked in a lot of oil.
4. Cannot start at the time.

At the end of each operation, empty the fuel tank, energize the spark plugs, and try to restart the engine to burn any remaining fuel in the tank. Repeat this process until the fuel in the engine is cleared.

Inject anti-corrosion oil and start the engine briefly to distribute the oil to the working parts. Do not inject this oil into the nozzle of the lubricator, as this may cause the O-ring of the carburetor to deteriorate.

Add solid lubricant to the camshaft and valve tappets to ensure that the camshaft is adequately lubricated during each operation.

Attention!

These maintenance procedures should be performed regularly. After a period of time, there may be a risk of corrosion or difficulty starting the engine. If you need help, please contact us.

Safety Information

Prohibited Actions:

- 1.This machine is only suitable for operation by adults aged 18 and above.
- 2.This machine uses pure gasoline as fuel,operates at high speed,and poses certain dangers.Operate strictly according to the manual.
- 3.Do not add any fuel other than gasoline.The fuel must be clean and kept away from fire sources.If the fuel contains excessive impurities,it may clog the carburetor passages and reduce engine performance.
- 4.When the machine is running,do not place hands or other objects near the engine pulley and flywheel,as this may cause bodily injury or increase the risk of machine damage.
- 5.If the machine cannot operate normally,do not force it to start.Immediately inspect the machine or contact after-sales service;otherwise,the risk of machine damage will increase.
- 6.The machine will produce noise and exhaust emissions during operation.Operate it in an open outdoor area whenever possible.
- 7.Regularly maintain the machine,change the oil,clean the oil passages,and inspect worn parts.This will significantly extend its operational life.

After-Sales Service

Thank you for choosing our company's model. We will provide you with satisfactory after-sales technical support.

We recommend carefully reading the assembly instructions, operation manual, and related precautions before building the model, as this will be very helpful. If you need technical support, contact our store staff.

1. After-Sales Service Standards

Images may differ from the actual product due to photography techniques, computer color variations, etc. The actual product color shall prevail.

Some products may have their parameters and structures improved or upgraded by the manufacturer without prior notice. Please refer to the actual product.

Before shipping, our company conducts detailed inspections and tests on each kit to ensure normal functionality. When the courier delivers the goods, please inspect them thoroughly to confirm their integrity. If damage occurs during shipping, have the logistics company issue a relevant certificate or refuse the delivery on the spot. Notify our company within 24 hours by email with photos; otherwise, the buyer assumes responsibility for any losses. For other model-related issues, contact us within 7 days.

Before using the model product, carefully read the assembly instructions and product operation manual, and follow the manufacturer's guidelines. Our company is not responsible for losses or injuries caused by failure to comply with the product usage instructions (e.g., water exposure, fire, disassembly, modification, etc.), nor for damages caused by intentional or accidental collisions.

Model products are inherently fragile, especially for beginners who may damage components quickly due to unfamiliarity. We ensure every part is tested before shipping. Therefore, we do not offer refunds or replacements for parts damaged within a short period unless the customer provides evidence of unused, brand-new condition. After verification by our staff, the entire set can be returned to the factory for repair, with return shipping costs covered by us. For other repairs, the buyer bears the return shipping costs.

If the customer claims the product does not meet the described functionality within three days of receipt, and this is confirmed by a government-recognized third-party agency (or our company), we will provide free repairs or part replacements. Customers may not request refunds or exchanges based on personal perceptions of performance differences (e.g., beginner operation errors), material differences, or other discrepancies.

For non-quality-related issues or damages requiring repairs, we provide repair services but charge for parts and labor. Transportation or mailing costs are the customer's responsibility.

Model products must be used under local government regulations and conditions. Our company is not liable for losses or injuries to users or third parties caused by improper use of the product or accessories.

For common usage knowledge and precautions, refer to the product manual.

The final interpretation right belongs to our company.

